



Brightness

- ▶ 3500 ANSI lumens
- ▶ Over 90% brightness uniformity across the screen

Contrast Ratio

- ▶ Greater than 250:1 ANSI, greater than 400:1 full field

Resolution/Digital Processing

- ▶ 3 chip 0.9" DMD™ (Digital Micromirror Device) system
- ▶ True XGA 1024x768 chip resolution
- ▶ 13 bit user selectable gamma table
- ▶ More than 1 billion displayable colors

Dynamic Scaling

- ▶ Resizing capabilities to scale down from 1600x1200 and up from 640x480 to the XGA resolution of DMD
- ▶ Independent horizontal and vertical size adjustment for graphics and video inputs

Power Lens Mount

- ▶ Fully-motorised (with manual override) lens focus, zoom, horizontal and vertical offset
- ▶ Unique ILS™ (Intelligent Lens System) – Lens position (zoom, focus, horizontal and vertical offset) is automatically recalled during channel switching
- ▶ Lens "bayonet-style" insertion system
- ▶ Lens mount tilt adjustment
- ▶ Built-in light shutter

Inputs

- ▶ Built-in RGB/YUV/YPbPr inputs allowing separate H and V syncs, composite sync and sync-on-green/luma (5 BNC connectors)
- ▶ Multi-standard Video Decoder Module (NTSC 3.58, NTSC 4.43, PAL, PAL 60, PAL M, PAL N, SECAM) with one composite video input (BNC and RCA connectors) and one S-video input (two BNC and 4-pin mini-DIN connectors)
- ▶ Built-in Audio Control Module with 4 stereo audio inputs and 1 stereo output (RCA connectors)
- ▶ Slot for an optional input module
- ▶ Full compatibility with Marquee Signal Switcher and third-party switchers

HDTV/DTV Compatibility

- ▶ Full HDTV/DTV compatibility on analogue RGB/YPbPr inputs
- ▶ Accepts 480i, 480p, 576i, 576p, 720p, 1035i, and 1080i formats at all applicable frame/field rates
- ▶ Accepts 1080p at 24, 25 and 30 Hz frame rates
- ▶ Optional HDTV Serial Digital Input Module

Various Keypads

- ▶ Standard hand-held IR backlit remote keypad, front and rear infrared sensors
- ▶ Built-in backlit keypad
- ▶ Optional RS422 two-way remote controller with LCD display using 6 pin XLR connector with range of 600ft (183m)
- ▶ Optional wired backlit remote keypad with 3 pin XLR connector

Control / Networking

- ▶ Third party control system and switcher compatibility
- ▶ Dual RS232 ports for computer control, with loop through for connection of multiple projectors
- ▶ Dual RS422 ports for connection of optional LCD two-way controllers and loop-through to multiple projectors up to 600ft (183m)

Diagnostics

- ▶ Built-in LCD diagnostic display indicates operational status and error messages
- ▶ Power and Status LED
- ▶ Full diagnostics through RS232 9 pin D connector

Graphical User Interface

- ▶ Auto Set-up feature
- ▶ "Direct Access" intuitive user interface for complete projector control in 5 world languages
- ▶ On screen user movable menus to fit different image aspect ratios (4:3, 5:4, 16:9, etc.)
- ▶ On screen help menus
- ▶ 100 channel memories
- ▶ Auto power feature

Lamp Specification/Color Temperature

- ▶ 1200W CERMAX® Xenon illumination system
- ▶ Pre-aligned lamp module
- ▶ Constant color temperature over the lamp life
- ▶ Color temperature adjustment range: 3200°K to 9300°K
- ▶ User replaceable lamp within 5 minutes
- ▶ Typical lifetime: 1,000 hours

Variable Lamp Power Supply/Light Output Control (LiteLOC™)

- ▶ "Auto Brightness" mode to maintain constant brightness over time
- ▶ "Lamp Conserve" mode to extend the lamp life
- ▶ "Max Brightness" mode for maximum light output

Power Requirements

- ▶ Line voltage 220V AC to 240 VAC +/- 10% @ 50/60 Hz
- ▶ Power consumption: 1500 W maximum
- ▶ Thermal dissipation: 5150 BTU/hr.

Weight and Size

- ▶ 39.9kg (88 lbs)
- ▶ 64.8cm (W) x 76.7cm (L) x 30.2cm (H)
- ▶ 25.48" (W) x 30.19" (L) x 11.88" (H)

Standard Accessories

- ▶ IR remote keypad with batteries
- ▶ User's Manual with warranty card
- ▶ 2.44m (8ft) line cord

Optional Accessories

- ▶ Serial Digital Input (SMPTE 259M/CCIR 601) with loop through feature
- ▶ Digital HDTV Input module (with loop through feature) compatible with all known HDTV formats
- ▶ PanelLink™ Input module
- ▶ Compatible with all Marquee Input modules
- ▶ RS422 Two-way remote LCD controller
- ▶ Replacement lamp module
- ▶ Remote infrared sensor
- ▶ Service Manual

Librarian

- ▶ Librarian
- ▶ Transit case

Regulatory Approvals

- ▶ CSA, UL and European safety approvals
- ▶ North American and European EMI/EMC approvals

Warranty

- ▶ One year parts and labour
- ▶ Accessories: 90 day

Due to constant research, specifications are subject to change without notice



Christie Digital Systems Inc
ImagePoint
58 Suttons Park Avenue,
Reading, Berkshire, RG6 1AZ,
United Kingdom
Tel: +44 (0) 118 926 6300
Fax: +44(0) 118 926 6322

Christie Digital Systems Inc
Hohenzollernstraße 124-126
41061 Mönchengladbach
Germany
Tel: +49 (0) 2161 664540
Fax: +49 (0) 2161 664546

Christie Digital Systems Inc
809 Wellington Street North,
Kitchener, Ontario,
Canada, N2G 4Y7
Tel: +1(519) 744-8005
U.S. customers call toll-free
1-800-265-2171
Fax: +1(519) 749-3136

Christie Digital Systems USA Inc
2037 Pointe Avenue,
Ontario, CA 91761
USA
Tel: +1(909) 923-3070
Fax: +1(909) 923-0703

Christie Digital Systems Inc
37 Tannery Lane,
#03-05 Tannery House,
Singapore 347790,
Tel: +65-749 5525
Fax: +65-744 2900



Take the stress and strain out of rental staging with the Roadster X4.

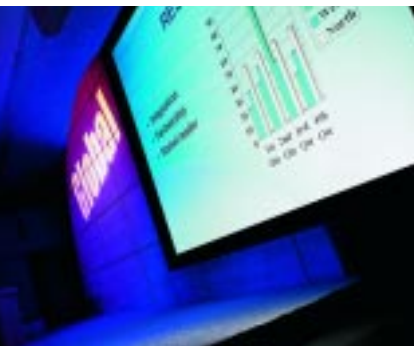

LCI - France



ARD German Election Coverage, - Germany



"La Bohème", - Italy

Everyone knows good things come in small packages, but did you know the Roadster X4 has everything you need for rental staging applications. Crammed full of features normally reserved for top of the line projection systems, the Roadster X4 is driven by the very latest in 3 chip DLP™ technology and is able to display from the widest range of sources with digitally perfect projection.

This workhorse projector outputs 3,500 ANSI lumens by way of a CERMAX, Xenon illumination system and provides full control over light output with constant color temperature. Better still by taking advantage of the X4's true digital capabilities, you can project HDTV and Digital Television images as they were intended - with film like images that simply cannot be matched by any other projection system.

In keeping with the Roadie series edict of offering purpose-built rental staging projectors, the Roadster X4 also utilises our unique Intelligent Lens System (ILS™). ILS allows lens position to be automatically recalled during channel switching for up to 100 sources. This fully motorised system takes the stress out of even the most sophisticated event.

The Roadster X4 takes the strain out of your events too. Built-in stackability, lens bayonet style insertion (for a full suite of fixed and zoom lenses) are some of the many benefits of a system that weighs in at just 39.9 kilos.



"La Bohème", - Italy



"The World Is Not Enough", EON Productions - Pinewood, UK



Macau handover - China

Roadster The World's 1st purpose-built projectors for Rental Staging

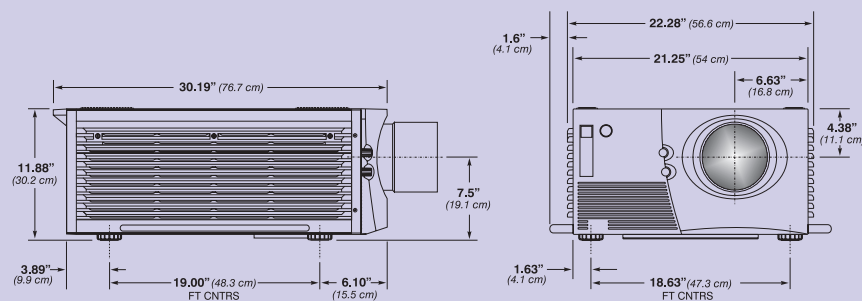

Rear view of Roadster X4 showing LCD display panel and inset keypad

- ▶ Upgradeable to higher brightness and SXGA resolution
- ▶ Self-stacking
- ▶ Fully motorized lens mount
- ▶ Built-in Light Shutter
- ▶ Variable Lamp Power Supply
- ▶ Auto set-up
- ▶ Consistent image quality
- ▶ Light Output Control
- ▶ Low sound level
- ▶ Xenon illumination system
- ▶ Full HDTV Compatibility
- ▶ Widest source compatibility, covering resolutions from VGA to VGX and HDTV
- ▶ Dynamic scaling
- ▶ Auto lock-in
- ▶ Universal AC voltage operation
- ▶ Optional lens suite