



# DLA-RS49U

4K Resolution  
Home Theater Projector

## REFERENCE SERIES



*The industry's most affordable 4K D-ILA projector, JVC's DLA-RS49, features e-shift3 technology that supports 4K sources up to 60p, JVC's Color Management System, outstanding 3D performance and 5 lens memory presets—all with a native contrast ratio of 60,000:1, and a dynamic contrast of 600,000:1.*

- 1080p three chip 3D enabled D-ILA projector
- New 6th generation 0.7-inch D-ILA devices
- New e-shift3 4K Precision (3840 x 2160) Projected Image
- Image—Upgraded feature
- **Native 4K inputs**
- 3840 x 2160 (24-30p, 60p at 4:2:0\*)
- 4096 x 2160 (24p)
- Clear Black processing
- Native contrast ratio of 60,000:1
- Intelligent Lens Aperture increases dynamic contrast ratio to 600,000:1
- 1.4 to 2.8:1 motorized zoom lens with Horizontal and Vertical offset
- Highly customizable built-in 2D to 3D converter creates dynamic 3D images from 2D video content
- Accepts all modern 3D formats (Blu-ray, side-by-side, top-and-bottom)
- Control: LAN / RS-232C / IR / 12 V Screen Trigger Output / Remote control with 3D functions
- New Remote Control App for smartphones and tablets
- 2 Year Warranty

Note: Optional 3D Glasses (PK-AG3) and 3D Synchro Emitter (PK-EM2) are required for viewing images in 3D.



# D-ILA® Newly Developed D-ILA Device

The exceptional picture quality achieved by JVC projectors is a result of the precision technology behind the D-ILA device. The new 6th generation device, with a 40% narrower pixel gap, achieves a 10% improvement in light efficiency for a brighter image with higher contrast and incredibly rich detail.



New 6th generation  
0.7-in. D-ILA device



Conventional device  
0.5µm



New D-ILA device  
0.3µm

a 40% narrower pixel gap from 0.5µm to 0.3µm achieves much brighter, higher contrast images

## 4K e-shift3 4K Precision JVC e-shift 3 Technology

Optimized for the new D-ILA device, new 4K e-shift3 shifts sub-frames by 0.5 pixel both vertically and horizontally to achieve 4-times the pixel density of the original content—boosting definition to the highest level yet.

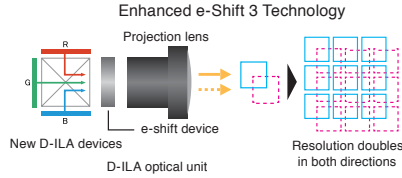

## Multiple Pixel Control (Scaler for 4K e-shift3)

The newest derivation of Multiple Pixel Control is a high-performance image processor that enables precise reproduction of Full HD sources on this 4K projector. New, Auto Mode performs frame adaptive filtering and picture generation to achieve an HD image optimized for a variety of scenes thereby enabling an immersive 4K experience without complicated picture adjustments.

### 4K e-shift3 Technology's Image Processor: Multiple Pixel Control

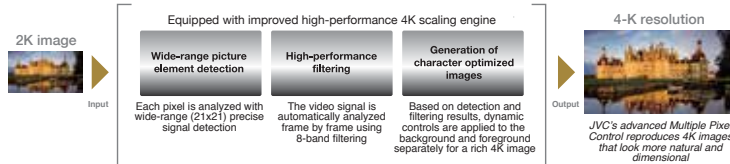

### Multiple Pixel Control in action

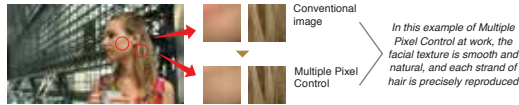

## External Dimensions (unit: inches | mm)

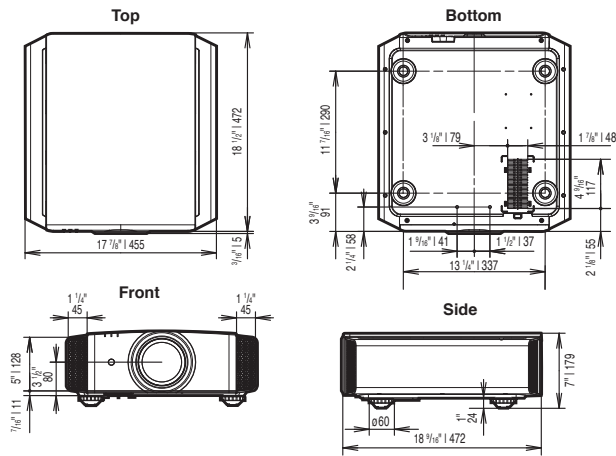

### Notes about viewing 3D video content

- The optional 3D Synchro Emitter and 3D glasses are required to view 3D images from the D-ILA projectors. 3D video software (3D media or output of 3D broadcasts) and a 3D-compatible video player are also required.
- Perception of 3D images will vary with individual viewers.
- Stop viewing 3D images immediately if any discomfort such as headaches, dizziness, eye fatigue, etc. occurs.
- Viewing of 3D images by children under the age of five is not recommended.
- Read the Safety Precautions in the User Manual carefully before viewing any 3D source.

- The projector is equipped with an ultra-high pressure mercury lamp, which may break, emitting a loud noise, when it is subjected to shock or after it has been used for some length of time.
- Please note that, depending on how the projector is used, there can be considerable difference between individual lamps regarding how many hours they will operate before requiring replacement.
- An additional payment is required for installation of a new lamp, if necessary.
- The projector lamp requires periodic replacement and is not covered by warranty.
- Please be aware that, because the D-ILA device is manufactured using highly advanced technologies, 0.01% or fewer of the pixels may be non-performing (always on or off).

Design and specifications are subject to change without notice. All pictures on this brochure are simulated. Adobe is a trademark or registered trademark of Adobe Systems Incorporated in the U.S. and/or other countries. HDMI, the HDMI logo and High-Definition Multimedia Interface are registered trademarks of HDMI Licensing LLC. All other brand or product names may be trademarks and/or registered trademarks of their respective owners. Any rights not expressly granted herein are reserved.

Copyright © 2014, JVC KENWOOD Corporation. All Rights Reserved.

## 60,000:1 Native Contrast Ratio

The combination of JVC's D-ILA device and the optical engine equipped with a new wire grid that improves polarization performance enables the DLA-RS49 to achieve an outstanding native contrast ratio of 60,000:1\*. The newly developed Intelligent Lens Aperture optimally adjusts black levels and Clear Black boosts contrast between light and dark enabling the DLA-RS49 to achieve an amazing dynamic range of 600:000:1.



Conventional Projector



DLA-RS49

\*As of Nov. 1, 2013, JVC data

## D-ILA 3D Projection\*

There's nothing like 3D to pull you into the scene. JVC's employs an original Frame Addressing method to reproduce 3D images with vivid colors, and the optical engine featuring the new D-ILA devices achieves more brightness than ever. Furthermore, 3D image adjustment functions such as Crosstalk Canceling are featured to offer the kind of realistic and exciting 3D images that only D-ILA can provide.

\*An optional 3D Synchro Emitter and 3D glasses are required to view 3D images.

## Smart-phone Remote Control App

Now, JVC D-ILA projectors can be controlled from your smartphone or tablet with a free remote control app. This app features an intuitive graphical UI and exclusive controls that make operations even easier. Additionally, there are built-in help functions for smoother operation.



## Optional Equipment



PK-L2312U  
User replaceable Lamp



PK-EM2  
RF 3D Synchro  
Emitter



PK-AG3  
RF 3D Glasses  
Battery-operated



## Connectors

## Specifications

		DLA-RS49
Device		0.7 inch Full HD D-ILA (1920 x 1080) x3
e-shift3 Technology		Yes
Resolution		3840 x 2160 (1920 x 1080 in 3D mode)
Lens		2X Zoom & Focus: Motorized f=21.4-42.8mm / F=3.2-4
Lens Shift		±80% Vertical and ±34% Horizontal (motorized)
Light Source Lamp		NSH 230W (lamp life: approx. 4000 hours when the lamp is in Low mode)
Contrast Ratio		Native: 60,000:1   Dynamic: 600,000:1
Connectors	HDMI	2 (3D/Deep Color/CEC compatible)
	3D Sync	1 (Mini DIN 3pin)
	RS-232C	1 (D-sub 9pin)
	LAN (RJ-45)	1
	Control and Firmware Upgrade	1
	Trigger	1 (Mini jack, DC12V/100mA)
Video Input Signal Format	Digital	480p, 576p, 720p 60/50, 1080i 60/50, 1080p 60/50/24 3840 x 2160p 60/50/30/25/24, 4096 x 2160p* 24
	PC Input Signal Format	HDMI VGA/SVGA/XGA/WXGA/FWXGA/WXGA+/SXGA/ WSXGA++/WSXGA+/WUXGA
Dimensions (WxHxD-inches)		17 7/8 x 7 x 18 9/16
Weight (net) (lbs)		32.41

\*When the video input signal is at 4096 x 2160p, data above 3,840 is not displayed equally on the left and right.

DISTRIBUTED BY



pro.jvc.com

Printed in the U.S.A.

"JVC" is the trademark or registered trademark of JVC KENWOOD Corporation.